

# CMR60 Series

Motor Run Capacitor – Metallized Polypropylene Film Motor AC Capacitor

**TRIGON**  
COMPONENTS



## FEATURES

- Protected in plastic case sealed with epoxy resin rated UL94V-0
- Very low dissipation factor
- High insulation resistance
- High thermal stability
- Excellent self-healing properties
- Suitable for electric fan, washer, refrigerator, air conditioner and other AC motor applications.

## ORDERING CODE

**CMR60 A 1 156 J 250 B**  
(1) (2) (3) (4) (5) (6) (7)

- (1) Motor Run Capacitor
- (2) Case and Fixing Device
- (3) Terminal Type
- (4) Capacitance
- (5) Tolerance Percentage on Capacitance
- (6) Voltage in VAC
- (7) Packing  
B=Bulk

※ Please refer to complete Ordering Code (CMRxx-Ord) for more ordering options.

## Dimension

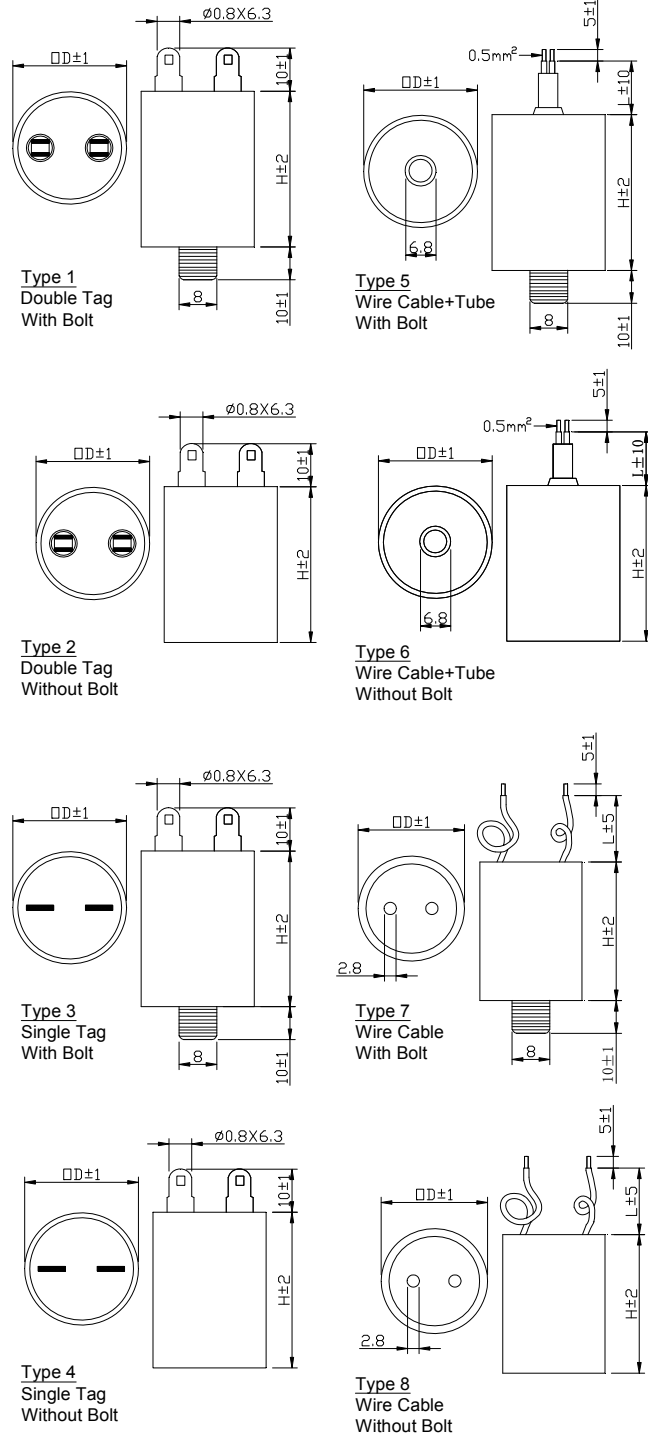

# CMR60 Series

Motor Run Capacitor – Metallized Polypropylene Film Motor AC Capacitor

**TRIGON**  
COMPONENTS

## General Technical Data

Technical Characteristics	GB/T7332-96 IEC384-2	
Operating Temperature	-25°C~+70°C	
Capacitance Range	1uF~100uF	
Capacitance Tolerance	J(±5%); K(±10%)	
Rated Voltage	250VAC 450VAC	
Withstand Voltage	AC ≥ 2U <sub>R</sub> 2S (1max ≤ 1.3In A)	
Withstand Voltage	AC ≥ 2500V 2S	
Dissipation Factor	≤ 0.004 1KHz	
Grade	P0 or P2	
dv/dt	250VAC	450VAC
	≥ 30	≥ 50
Safety Approval	UL, cUL and VDE	

Capacitor

## Dimension (mm)

CAP	TYPE 1/3/5		TYPE 2/4/6				TYPE 7				TYPE 8					
	250V AC		450V AC		250V AC		450V AC		250V AC		450V AC		250V AC		450V AC	
uF	OD	H	OD	H	OD	H	OD	H	OD	H	OD	H	OD	H	OD	H
1	26	55	26	55	26	55	26	55	26	55	26	55	26	55	26	55
2	26	55	26	55	26	55	26	55	26	55	26	55	26	55	26	55
3	26	55	26	55	26	55	26	55	26	55	26	55	26	55	26	55
5	26	55	34	55	26	55	34	55	26	55	34	55	26	55	34	55
6	26	55	34	55	26	55	34	55	26	55	34	55	26	55	34	55
8	26	55	36	65	26	55	36	60	26	55	36	60	26	55	36	55
10	34	55	36	65	34	55	36	60	34	55	36	60	26	55	36	55
12	34	55	36	75	34	55	36	70	34	55	36	70	26	55	36	65
16	34	55	45	75	34	55	45	70	34	55	45	70	34	55	45	65
20	34	55	45	75	34	55	45	70	34	55	45	70	34	55	45	65
25	36	65	45	85	36	60	45	80	36	60	45	80	34	55	45	75
30	36	65	50	85	36	60	50	80	36	60	50	80	34	55	50	75
40	45	75	45	125	36	70	45	120	36	70	45	120	36	65	45	115
50	45	75	50	125	45	70	50	120	45	70	50	120	45	65	50	115
60	50	85	60	125	50	80	60	120	50	80	60	120	50	75	60	115
80	45	125	60	145	45	120	60	140	45	120	60	140	45	115	60	135
100	50	125	65	145	50	120	65	140	50	120	65	140	50	115	65	135

\*Custom dimension available on request.

# CMR60 Series

Motor Run Capacitor - Metallized Polypropylene Film Motor AC Capacitor

TRIGON  
COMPONENTS

## DIELECTRIC TYPICAL PROPERTIES

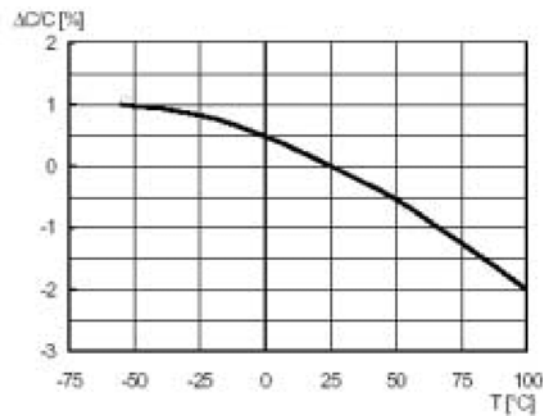
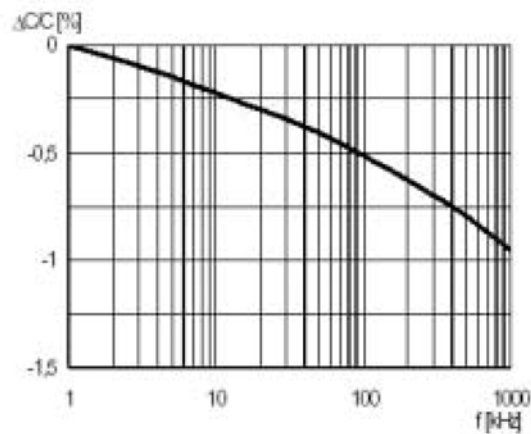
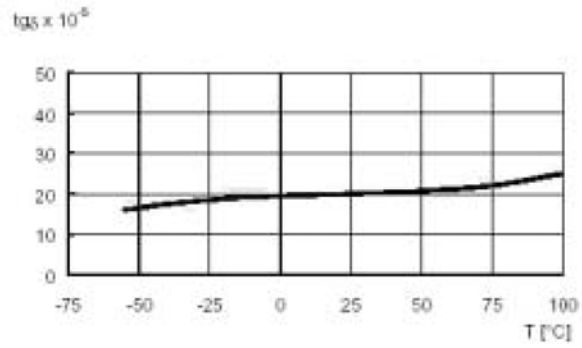
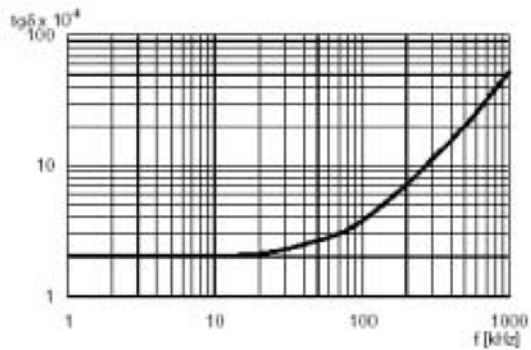

$M\Omega \times \mu F$  [s]

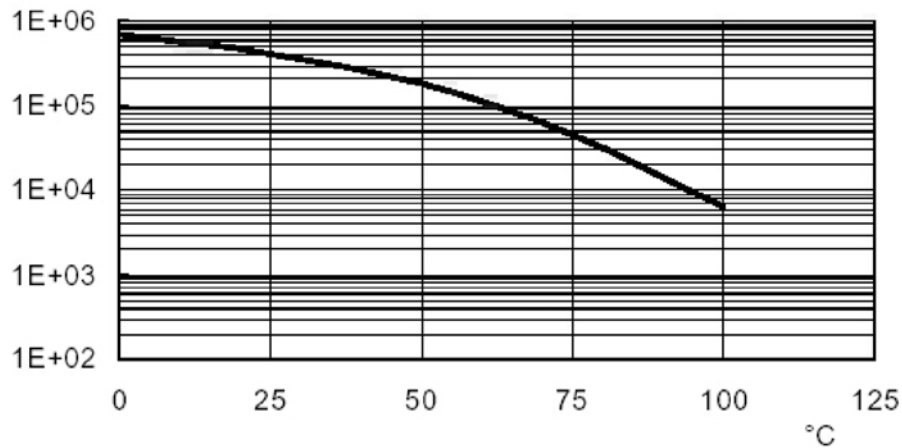

Capacitor

# CMR60 Series

Motor Run Capacitor - Metallized Polypropylene Film Motor AC Capacitor

TRIGON  
COMPONENTS

## GENERAL INFORMATION

### TECHNICAL TERMS EXPLANATION

**Rated capacitance of the capacitor C ( $\mu\text{F}$ ):** the capacitance value for which the capacitor has been designed, measured at 20°C at frequency of 1KHz.

**Rated voltage Un (V):** the effective value of voltage for which the capacitor has been designed. **Rated frequency Fn (Hz):** the highest value of frequency for which the capacitor has been designed **Rated current In (A):** the effective value of alternating current to the rated voltage and frequency.

**Minimum operating temperature (°C):** the minimum permissible temperature on the external surface of the capacitor can during its working.

**Maximum operating temperature (°C):** the maximum permissible temperature over the external surface of the capacitor can during its working.

**Capacitor for continuous and intermittent working:** a capacitor designed to work at a certain voltage during continuous working and at a different voltage (normally higher) during intermittent working. **Working classes:** the total length of minimum life for which the capacitor has been designed under conditions of voltage, temperature, frequency, rated cycle:

- Class A 30.000 hours
- Class B 10.000 hours
- Class C 3.000 hours
- Class D 1.000 hours

These working classes expect a failure rate not higher than 3% during the life of the capacitor.

**Climatic category:** is specified by three digits (IEC 60068-1). The first number represents the lower limit, the second one represents the higher limit, and the third one represents the number of days necessary to the humidity test (example 25/85 /21).

**Dissipation of a capacitor (W):** the dissipated active power of the capacitor.

**Dissipation factor ( $\text{tg}\delta$ ):** the relation between the resistance equivalent series and the capacitive reactance to an alternating sinusoidal voltage and to a specific frequency.

**Insulation Resistance:** the relation, measured by M., between a continuous voltage applied to the capacitor and the creepage current after one charge minute.

**Capacitive current of creepage (A):** the current passing a conductor which connects the metallic can to the ground when the capacitor is powered by an alternating current system with the grounded neutral. **Resistance to transistor:** pulse rise time (dv/dt). It characterizes the capacitance of a capacitor to withstand current peaks due to fast changes of voltage. The peak current is quantifiable by the following formula:  $I_{\text{PEAK}} (\text{A}) = C (\mu\text{F}) * dv/dt (\text{V}/\mu\text{S})$

### Working and Safety conditions

**Application:** the capacitors described in the current catalogue are specifically designed for the start and the run of single-phase electric motors. Usually the capacitor is connected in series to an inductive winding into an auxiliary circuit for a single-phase motor or in parallel phase/phase into three-phase motors when powered by a single-phase circuit.

**Safety class:** the degree of safety is marked on the capacitor according to the following symbols:

- (P2) the capacitor has been designed to fail only in case of circuit cut-off and it is protected against fire and electrocution risk.
- (P1) the capacitor can fail either by a circuit cut-off or by a short-circuit and it is protected against fire and electrocution risk.
- (P0) in case of failure, the capacitor does not have any particular protection.

**Safety device:** Trigon produces capacitors according to high level of process and quality control. During the usual working, due to external stresses or at the end of the life, the capacitor can stop working. In order to guarantee a better internal safety, the internal pressure due to gas in case of overheating causes the expansion of the groove disconnecting the capacitor from the electric network.

**Rated Voltage:** is the highest continuous voltage applicable to the capacitor at rated temperature. Higher continuous voltage may cause the perforation of the dielectric or a short-circuit. The material used as dielectric owns a typical property, well-known as "self-healing": in case of discharge, the temperature creates a localized demetallization which insulates the discharge process. The rated voltage belongs to the alternating sinusoidal type.

# CMR60 Series

## Motor Run Capacitor - Metallized Polypropylene Film Motor AC Capacitor

**TRIGON**  
COMPONENTS

**Dissipation:** the power dissipated by the capacitor is quantifiable by the following formula:  $P_{\max}(W) = 2 \cdot \tan \delta \cdot C \cdot V_{2RMS}^2$

The current passing the capacitor causes a heating of the component. If the heat is excessive, the performances of the component can get worse to the short-circuit, the out-of-working and the fire risk. If the current applied is generated by a periodical sine wave, the whole cartridge could heat. It will be necessary to check the temperature does not exceed the maximum permissible limit.

If the current is generated by non-periodical waves (pulse and harmonic currents) a heating localized over the terminals could occur, in addition to an heating of the component. In this case, it will be necessary to check the sealing of the capacitor at current peak (dv/dt).

**Ionization processes:** the dielectric strength is the key characteristic to choose a dielectric material. Increasing the voltage, there is a value where the dielectric loses his insulating properties and the passage of a strong conduction current occurs: this is the discharge process. Even if the discharge is generally a thermal process, it is important to know the voltage applied: normally, the dielectric strength has minimum values with alternating voltages (thermal discharge) and maximum values with pulse voltages (electronic or intrinsic discharge). Together with these two processes, there is to consider the process of partial discharges due to the ageing of the material and to external stresses, some vacuoles are born, points of partial discharges. These discharges cause a progressive expansion of empty spaces with and a consequent erosion process taking to the definitive discharge.

**Storage:** particular conditions of temperature and relative humidity may cause a deterioration of the electric characteristics of the capacitor.

We suggest the following parameters in order to carry out a correct storage: Temperature: from 5 to 50° C

Humidity

.. Average yearly value:  $\leq 60\%$

.. All other days:  $\leq 70\%$

.. For 30 days spread over the year (statistical data):  $\leq 80\%$

### Expected Life

Any material or element has a longer or shorter life according to the working conditions to which it is submitted and to its intrinsic property. The capacitor is submitted to several types of stresses: over voltages, overheating, pollution, humidity, radiations, vibrations ..... The ageing is an irreversible change of the properties as a result of the application of an external stress. The expected life is time necessary to the capacitor to reach the expected limit value. The main stresses have electric and thermal origin. It is possible to assume a model of life for each series of product and type of stress so as to expect the life of the component in function of temperature and voltage applied.

$$L \text{ (hours)} = F(V, T)$$

In the catalogue, here below, the curves of expected life in function of the voltage applied to the component, referred to rated temperature. These curves refer to life tests fixed by EN60252 standard where it is allowed a maximum variation of capacitance of 3%.

Please get in touch with us for further details.

### Materials

The materials used for capacitors are the result of long experience and constant attention to field improvements. Trigon, certified according to ISO9001 standard, selects its suppliers and carries out systematical checks to the step of materials acceptance. All materials to our present knowledge are nontoxic and free from: Cadmium, Mercury, Chrome and compound, PCB (PolyChlorineTriphenyl), Bromide and Chlorine Dioxins, CFC e HCFC, Asbestos.